

No. 638,431.

Patented Dec. 5, 1899.

E. WERNER.
GRINDING MACHINE.

(Application filed June 27, 1898.)

(No Model.)

2 Sheets—Sheet 1.

-FIG. I-

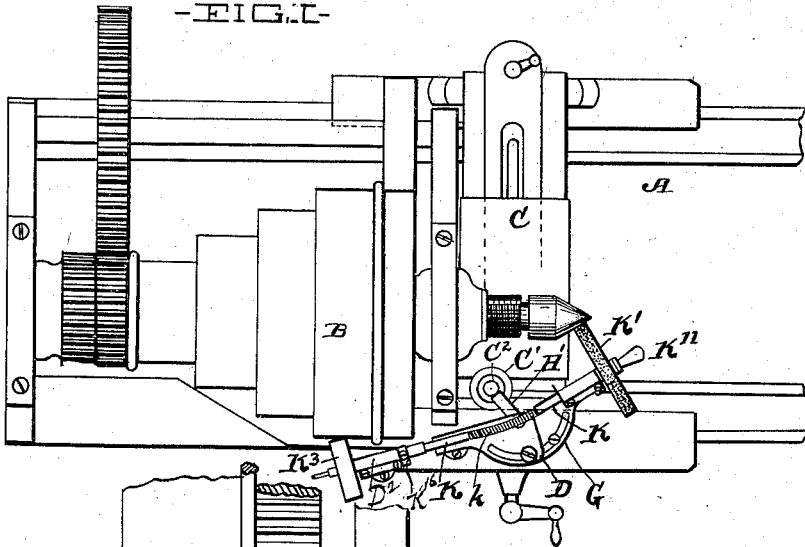

-FIG. II-

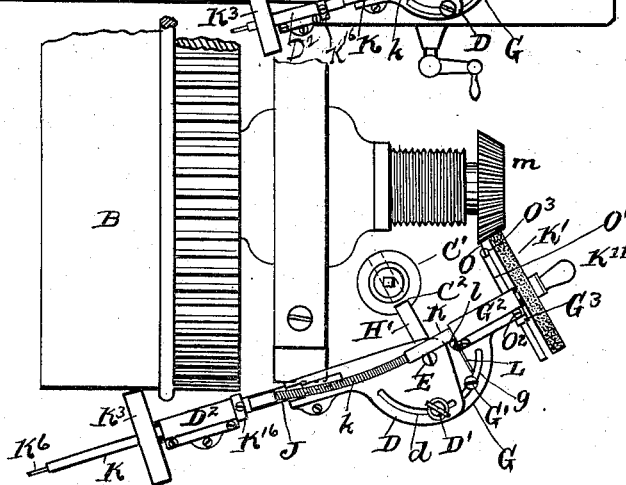

-FIG. III-

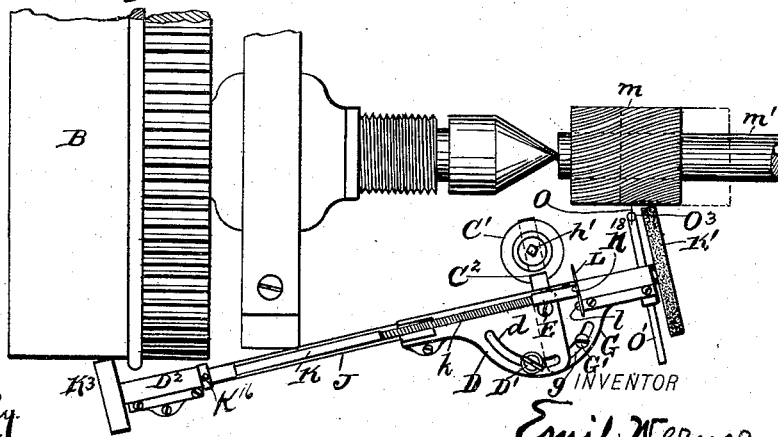

WITNESSES:
Daniel E. Daly
Anna H. Penatt

INVENTOR
Emil Werner
 BY
Sydney Dorer & Donnelly
 ATTORNEYS

UNITED STATES PATENT OFFICE.

EMIL WERNER, OF CLEVELAND, OHIO.

GRINDING-MACHINE.

SPECIFICATION forming part of Letters Patent No. 638,431, dated December 5, 1899.

Application filed June 27, 1898. Serial No. 684,544. (No model.)

To all whom it may concern:

Be it known that I, EMIL WERNER, of Cleveland, county of Cuyahoga, and State of Ohio, have invented certain new and useful Improvements in Grinding-Machines; and I do hereby declare the following to be a full, clear, and exact description of the invention, such as will enable others skilled in the art to which it pertains to make and use the same.

My invention relates to improvements in grinding-machines, and more especially to a lathe attachment designed for use in grinding lathe-centers and cutters or mills.

The primary object of the invention is to provide an attachment of the character indicated that is applicable to different sizes and styles of lathes and other machines and that is simple, convenient, and reliable.

With this object in view the invention consists in certain features of construction and combinations of parts hereinafter described, and pointed out in the claims.

In the accompanying drawings, Figures I, II, III are top plans of a portion of a lathe provided with my improved grinding attachment. Fig. IV is a side elevation, mostly in central longitudinal section, of the left-hand portion of the attachment. Fig. V is a side elevation, partly in central longitudinal section, of the right-hand portion of the attachment. Fig. VI is a transverse vertical section on line VI VI, Fig. IV. Fig. VII is a transverse vertical section on a portion of line VII VII, Fig. IV. Fig. VIII is a top plan of a portion of the attachment. Fig. IX is a transverse vertical section on line IX IX, Fig. V.

Referring to Figs. I, II, and III of the drawings, A designates a lathe; B, the suitably-driven cone-pulley of the lathe; C, the rest, and C' the rest's block or post that has a lateral hole or socket C² for receiving a tool (not shown) employed in the operation of the lathe and instrumental in the appendage to the lathe of my improved attachment that comprises two plates D and G, that are arranged the one, D, above and overlapping the other, G, and pivoted vertically at or near their rear edges, preferably by a screw E, (see Figs. V and VIII,) to a base H, that is provided with a correspondingly-threaded hole h, engaged by the screw E. Base H has

a rearwardly-extending arm H' capable of fitting the tool-receiving socket or hole of the tool-post and rigidly secured to the said post by the screw h', that engages the said arm through a correspondingly-threaded hole in the post. Plate D, near its forward edge, is provided with an elongated slot d, that is arranged concentrically of the pivot E. Plate G is provided with a similar elongated slot g, that is arranged concentrically of the pivot E. The plates D and G are adjustable circumferentially of their axes, that are, as already indicated, coincident, and means for securing the said plates in the desired adjustment is provided and comprises, preferably, two screws D' and G'. The two slots d and g register or are capable of registering with each other. Screw D' has its head overlapping the upper side of plate D and extends vertically through the slots d and g and engages a correspondingly-threaded hole H², formed in the base H. Screw G' extends through the slot g, has its head overlapping the upper side of the plate G, and has its shank extending vertically through the slot g into a correspondingly-threaded hole H³, formed in the base. The screws D' and G' are arranged the distance apart required to accommodate the desired circumferential adjustment of the plates, and the slots d and g are long enough to accommodate the said adjustment. The lower plate G is secured in the desired adjustment by tightening the screw G', and thereby causing the head of the said screw to clamp the said plate upon the base. The upper plate D is secured in the desired adjustment by tightening the screw D' and causing the head of the said screw to clamp both plates D and G downwardly upon the base.

The horizontally-arranged shaft K, that bears the grinding-wheel, is suitably supported from both plates D and G, and the said shaft, to render it capable of yielding or accommodating itself to the movement or adjustment of the said plates circumferentially of the latter's axes, has its central portion composed of a spiral spring or other suitable laterally-flexible member—that is, the shaft comprises three sections, two outer and inflexible sections and a central and laterally-flexible section that is composed, preferably,

of a spiral spring k , having opposite ends secured to the different outer sections, respectively, in any approved manner. One of the outer sections—the right-hand section in the case illustrated—is provided with the grinding-wheel K^1 , that is composed of emery or other suitable material, and the said shaft-section has bearing and is shiftable endwise of a box G^2 , that is formed upon the right-hand end of the plate G . The left-hand outer section of the shaft has bearing within the endwise-adjustable sleeve K^2 , that operatively bears the driving-wheel K^3 , that is preferably a friction-pulley designed to be driven through frictional contact with the lathe's cone-pulley and arranged at the left-hand or outer end of the box D^2 , wherein the said sleeve has bearing, which box is supported in any approved manner from the plate D . The operative connection between the sleeve K^2 and the shaft is one that enables the shaft to slide endwise without interrupting or interfering with the rotation of the shaft and consists, preferably, of a groove K^4 , formed in and longitudinally of the shaft and engaged by feathers or pins K^5 , that project into the said groove and are rigid with the sleeve. The left-hand shaft-section at its outer end is provided with a thumb-and-finger piece or holder K^6 , whose connection with the shaft is such that it can be taken hold of and held in the reciprocation of the shaft without interfering with the shaft's rotation, and the said connection comprises, preferably, a bore or socket formed in and arranged axially of the outer end of the said shaft-section and engaged by the inner end of the holder and a pin or projection K^7 internally of the said socket and rigid with the surrounding wall of the socket's chamber and engaging an annular groove or recess K^8 , formed in the socket-engaging portion of the holder.

The grinding-wheel, as already indicated, is carried by the right-hand section of the shaft, and the operative connection between the said wheel and the shaft comprises, preferably, a collar K^9 , formed upon the shaft at the right-hand end of the box G^2 , and a nut K^{10} , that is mounted upon the correspondingly-threaded right-hand end of the said shaft-section and clamps the said wheel against the collar K^9 . The said nut at its outer end is provided with a thumb-and-finger piece or holder K^{11} , and the connection between the said holder and the nut is such that the latter can be held as required in moving the shaft endwise through the instrumentality of the said holder without interrupting or interfering with the rotation of the shaft, and the said connection consists, preferably, of an arm K^{12} , formed upon and projecting inwardly from the holder and provided at its free end with a head or shoulder K^{13} , that overlaps the inner side of a plate K^{14} , that is removably secured to the outer end of the nut, preferably by means of screws

K^{15} , and is perforated centrally to accommodate the location of the said arm.

In Fig. I my improved grinding attachment is shown in position operating upon a lathe-center and shows the manner of transmitting power to the shaft of the attachment from the lathe-pulley. As the center or other device that is operated upon by the grinding-wheel is located inwardly from and out of line with the driving extremity of the lathe-pulley, the importance of the provision of a flexible section in the composition of the shaft and the adjustment of the two inflexible sections of the shaft at different angles to each other is obvious. A collar K^{16} is adjustably mounted upon the sleeve K^2 at the right-hand end of the box D^2 , and the said collar is secured in the desired adjustment, preferably, by a screw K^{17} , that engages the sleeve through a correspondingly-threaded hole formed in the collar. By loosening the screw the shaft-pulley is adjustable toward or from the grinding-wheel, and as the distance between the point of power transmission and the point at which the grinding operation takes place varies with different lathes and machines the importance of being able to lengthen or shorten the distance between the grinding-wheel and the shaft-pulley is obvious. The box D^2 is preferably mounted upon a rod or bar J , that is arranged below and parallel with the pulley-carrying sleeve K^2 and is supported from the plate D . The said bar J is secured to the plate D , preferably, by a clamp D^3 , (see Fig. VII,) that consists of two jaws that embrace opposite sides, respectively, of the bar and are integral with the plate, and a screw that engages correspondingly-threaded and registering holes formed in the said jaws. The box D^2 is secured in the desired adjustment upon the said bar, preferably, by a clamp J^2 , (see Fig. VI,) that consists of two jaws integral with the box and arranged to clamp opposite sides, respectively, of the bar and held in their clamping or operative position by a screw that engages correspondingly-threaded and registering holes formed in the said jaws. This manner of supporting the box J from plate D enlarges the facility and the range of the adjustability of the shaft-pulley from the grinding-wheel.

In Fig. II the grinding attachment is shown in position ready for operation upon an angular mill or cutter m , and in this case a rest for the cutter's tooth that is to be ground is provided and consists, preferably, of a sheet-metal piece O , that is supported from a bar O' , that has bearing and is adjustable endwise of a box G^3 , that is rigid with the plate G at the under side of the grinding-wheel-bearing section of the shaft and arranged transversely of and preferably at right angles to the box G^2 . Bar O' is secured in the desired adjustment, preferably, by a screw O^2 , that extends through a correspondingly-threaded hole formed in the box into engagement with the said bar. The said bar O' ex-

tends rearwardly, and at its rear end is provided with an upright post O^3 , that is adjustable circumferentially and secured in the desired adjustment, preferably, by a clamp, (see Fig. IX,) that consists of two jaws $O^4 O^4$, that are formed integral with the bar and are arranged to clamp opposite sides, respectively, of the post and are secured in their clamping or operative position by a screw O^5 , that engages correspondingly-threaded and registering holes formed in the jaws, and the rest O is supported from and extends laterally of the upper end of the said post, and at its inner end extends between the two jaws of a clamping device O^6 , that is formed upon the upper end of a post, and comprises also a screw O^7 , that engages correspondingly-threaded and registering holes formed in the said jaws. It will be observed, therefore, that the rest is adjustable circumferentially up and down, rearwardly and forwardly, and at various angles, and, in fact, into any position that may be required in order to accommodate itself to any form or size of mill or cutter. The rest O has a seat O^8 , for the cutter's tooth that is being ground, and the said seat is preferably quite short, so as to render the rest better adapted for all forms of teeth.

In operating upon a center and upon narrow mills or cutters the grinding-wheel is fed along the tooth by the manipulation of the thumb-and-finger piece at the one or the other end of the shaft that carries the said wheel. In grinding long mills or cutters it is more desirable and convenient to feed the mill or cutter by hand transversely of the face of the grinding-wheel, and, as shown in Fig. III, (that exhibits a comparatively long mill or cutter,) the cutter or mill is slidably mounted upon a rod or bar m' , that is arranged and supported in any approved manner; but in this case means for preventing endwise displacement of the shaft K is provided and consists, preferably, of a latch L , that is arranged at the left-hand end of the box G^2 , pivoted, as at l , horizontally and longitudinally of the shaft to the left-hand end of the said box and capable of tilting vertically and adapted when in its rearwardly-tilted position to engage the annular groove or recess K^{18} , formed in the said shaft-section, and thereby positively prevent endwise displacement of the shaft when the grinding-wheel is operating upon a mill or cutter that is fed by hand in lieu of feeding or shifting the grinding-wheel during the grinding operation.

In Figs. III, V, and VIII the latch L is shown in engagement with the groove K^{18} .

What I claim is—

1. In a grinding-machine of the character indicated, the combination with the suitably-supported and suitably-shiftable grinding-wheel-carrying shaft provided with a groove or recess, of a latch arranged to engage the said groove or recess in its operative position, substantially as and for the purpose set forth.

2. In a grinding-machine of the character

indicated, the combination with the suitably-supported and suitably-driven endwise-shiftable grinding-wheel-carrying shaft provided with an annular groove or recess, and a pivoted latch having its axis arranged parallel with the shaft and adapted or arranged to engage the said groove or recess in its operative position, substantially as and for the purpose set forth.

3. In a grinding-machine of the character indicated, the combination of the grinding-wheel-bearing shaft shiftable endwise; a suitably-supported bar arranged below and parallel with the one end portion of the shaft; two boxes supporting the shaft a suitable distance apart, and one of the said boxes being adjustably mounted upon the said bar; means for securing the said box in the desired adjustment; a suitably-driven sleeve operatively mounted upon the shaft and having bearing in the said adjustable box; substantially as set forth.

4. In a grinding-machine of the character indicated, the combination of the grinding-wheel-carrying shaft; a suitably-supported endwise-shiftable bar arranged parallel with the shaft; means for securing the said bar in the desired adjustment; two boxes supporting the shaft a suitable distance apart, and one of the said boxes being adjustably mounted upon the aforesaid bar; means for securing the said adjustable box in the desired adjustment; a sleeve operatively mounted upon the shaft and having bearing in the adjustable box; a driving-wheel operatively connected with the sleeve at one end of the last-mentioned box, and a collar adjustably fixed upon the sleeve at the opposite end of the said box, substantially as and for the purpose set forth.

5. In a grinding-machine of the character indicated, the combination of a base; two horizontally-arranged plates adjustable upon the base independently of each other; means for securing the plates in the desired adjustment; a grinding-wheel; a driving-wheel, and a shaft comprising a central flexible section and two inflexible sections bearing the grinding-wheel and driving-wheel, respectively, and attached to opposite ends, respectively, of the central section, and supported from the different plates, respectively, substantially as and for the purpose specified.

6. In a grinding-machine of the character indicated, the combination of a base; two horizontally-arranged plates overlapping each other and pivoted to the said base, and adjustable concentrically of the pivot; means for securing the plates in the desired adjustment, and the suitably-driven grinding-wheel-carrying shaft comprising a central flexible section and two inflexible sections that are attached to opposite ends, respectively, of the central section and are supported from the different plates, respectively, substantially as and for the purpose set forth.

7. In a grinding-machine, the combination of a base; two plates pivoted to the base and

adjustable independently of each other circumferentially of the pivot; means for securing the plates in the desired adjustment; a grinding-wheel-carrying shaft-section supported from one of the said plates; a driving-wheel-carrying shaft-section supported from the other plate, and such an operative connection between the said shaft-sections as will accommodate the adjustment of the aforesaid plates without interfering with the transmission of motion from the last-mentioned shaft-section to the first-mentioned shaft-section, substantially as set forth.

8. In a grinding-machine, the combination of a base; two plates pivoted to the base and adjustable independently of each other circumferentially of the pivot; means for securing the plates in the desired adjustment, and comprising screws instrumental in clamping the plates downwardly upon the base, and the plates being slotted concentrically of their axes to accommodate the location of the said screws and the circumferential adjustment of the plates; a grinding-wheel-carrying shaft-section supported from one of the said plates; a driving-wheel-carrying shaft-section supported from the other plate, and such an operative connection between the said shaft-sections as will accommodate the adjustment of the aforesaid plates without interfering with the transmission of motion from the last-mentioned shaft-section to the first-mentioned shaft-section, substantially as set forth.

9. In a grinding-machine, the combination of a shaft comprising an inflexible grinding-wheel-carrying section; an inflexible driving-wheel-carrying section; and a connection between the said inflexible sections composed of suitably-coiled wire; a base; two plates pivoted to the said base and adjustable concentrically of the pivot and independently of each other and supporting the different inflexible shaft-sections, respectively, and means for securing the plates in the desired adjustment, substantially as set forth.

10. A grinding attachment, comprising a base having a rearwardly-extending arm; two

plates pivoted to the base and adjustable circumferentially of the pivot; suitably-driven shaft comprising two sections supported from the different plates, respectively, and operatively connected with, and adjustable at different angles relative to each other, and a grinding-wheel operatively connected with one of the said shaft-sections, substantially as set forth.

11. A grinding attachment comprising a base; two plates adjustably arranged upon the base; means for securing the plates in the desired adjustment; a suitably-driven shaft comprising two sections supported from the different plates, respectively, and operatively connected with and adjustable at different angles relative to each other; a grinding-wheel operatively connected with one of the said shaft-sections; a rest instrumental in supporting the object to be ground, and a bar arranged below and transversely of the grinding-wheel-bearing shaft-section and supported from the plate that bears the said shaft-section and bearing the aforesaid rest.

12. A grinding attachment comprising a base; two plates adjustably arranged upon the base; means for securing the plates in the desired adjustment; a suitably-driven shaft comprising two sections supported from the different plates, respectively, and operatively connected with and adjustable at different angles relative to each other; a grinding-wheel operatively connected with one of the said shaft-sections; a bar arranged below and transversely of the grinding-wheel-bearing shaft-section and supported from the plate that bears the said shaft-section; an upright post adjustably supported from the said bar, and a rest, that is instrumental in supporting the object to be ground, adjustably supported from the said post, substantially as shown, for the purpose specified.

Signed by me at Cleveland, Ohio, this 1st day of June, 1898.

EMIL WERNER.

Witnesses:

C. H. DORER,
ANNA H. PANATT.